

# TURBIDITY CONTROLLER TURBISWITCH GS5



## SAFETY PRECAUTIONS

- Installation, initial start-up and maintenance may only be performed by trained personnel.
- The device may only be connected to supply power which complies with the specifications in the technical data and on the serial plate.
- The device must be disconnected from all sources of power during installation and maintenance work.
- The device may only be operated under the conditions specified in the operating instructions.

## DESCRIPTION

The TURBISWITCH GS5 controller relay, in conjunction with one of its associated probes, is an optical turbidity measurement for determining the solid content in a liquid medium.

It allows to detect a threshold of blurring / turbidity of the water, previously determined by the user.

The measurement is based on the principle of optical attenuation, i.e. the reduction of light due to undissolved solids in the liquid. The measurement is insensitive to external light.

If the defined turbidity value set by user is exceeded or fallen below, the output relays of the TURBISWITCH GS5 commute.

**Attention: it is not possible to associate controller TURBISWITCH GS5 with sensors from TRUBOMAT series (TT-GS, TR-GS and CP1) !**

## TECHNICAL DATA

|                     |                                                                                                                                                                                        |
|---------------------|----------------------------------------------------------------------------------------------------------------------------------------------------------------------------------------|
| Power supply        | 100...240V AC / 50...60Hz (TURBISWITCH GS5 G) or<br>10...30V DC and 12...24V AC (TURBISWITCH GS5 D)                                                                                    |
| Power consumption   | 1...5W                                                                                                                                                                                 |
| Ambient temperature | -10...+45°C                                                                                                                                                                            |
| Output relays       | 2x potential free contacts (NO) for turbidity alarm<br>(commute when turbidity value reaches user set trigger point)<br>1x potential free contact (NO) for measurement error detection |

**Normally Open : all contacts are open when supply power is switched off**

Output relay switching capacity 250V AC, 3A / 30V DC, 1A

**Note: contacts are not protected against current overload. Please use external protective device.**

|                         |                                                                                                                                                                          |
|-------------------------|--------------------------------------------------------------------------------------------------------------------------------------------------------------------------|
| Housing dimensions      | 22.5x100x122mm                                                                                                                                                           |
| Top-hat rail dimensions | 35x7.5mm (DIN EN 60715)                                                                                                                                                  |
| Protection              | IP40                                                                                                                                                                     |
| Connector terminals     | Screw terminals, max. 1.5mm <sup>2</sup>                                                                                                                                 |
| Limit value             | 3 turbidity measuring ranges, depending on the solid content : LOW, MEDIUM, HIGH. Each one displayed as [0..100%]<br>Adjustment steps: LOW = 5%; MEDIUM = 2%; HIGH = 1%. |
| Switch Back Hysteresis  | Adjustable 1...25% of set measuring range                                                                                                                                |
| Cable length            | Max. 100m between sensor and controller                                                                                                                                  |
| Display                 | 2½-place LED, 5x7 pixel matrix display                                                                                                                                   |
| Settings                | Rotary/pushbutton selector on front panel                                                                                                                                |
| Switching delay         | Adjustable 0,1...9,9 seconds                                                                                                                                             |

**CE Mark: The device fulfills the legal requirements of applicable EU-guidelines.**

**BAMO** INTERNATIONAL

22, Rue de la Voie des Bans · Z.I. de la gare · 95100 ARGENTEUIL

Tel +33 (0)1 30 25 83 20 Web [www.bamo.eu](http://www.bamo.eu)

Fax +33 (0)1 34 10 16 05 E-mail [export@bamo.fr](mailto:export@bamo.fr)

**TURBIDITY CONTROLLER  
TURBISWITCH GS5**

**TUR**

**410-03/1**

29-01-2024

M-410.03-EN-AD

## DISPLAYS ON THE CONTROLLER

|              |                                                                         |
|--------------|-------------------------------------------------------------------------|
| Yellow LEDs: | Selected measuring range: 1 LED = LOW / 2 LEDs = MEDIUM / 3 LEDs = HIGH |
| Blue LED:    | LED on: Limit value reached; LED off: Limit value not reached           |
| 0-100:       | Selected limit value (%) in the specified measuring range               |
| TR:          | Receiver malfunction or receiver not connected                          |
| TT:          | Emitter malfunction or emitter not connected                            |
| CR:          | Memory error (perform reset to factory settings)                        |
| ST:          | Default values (after reset to factory settings)                        |
| ER:          | Excessive number of transmission errors during digital transmission     |
| HT:          | High Temperature alarm                                                  |
| LT:          | Low Temperature alarm                                                   |

For pipe mounted sensors (TURBISWITCH GA...), the blinking green LEDs in the connection head of the TT-HDR transmitters and TR-HDR receivers indicate a proper functioning (in case of a failure : fixed or red light).

## RELAY OPERATION LOGIC

The blue LED is off: turbidity of the medium is below the set limit value. The relay for "below limit value" is open.  
The blue LED is on: turbidity of the medium is above the set limit value. The relay for "exceeded limit value" is open.

## SETTING OF CONTACT THRESHOLDS

Selection of 0..100% by turning the rotary/pushbutton switch.

**Switching from one measuring range to another is done automatically by continuing to turn the rotary/push switch.**

The selected range (LOW/MED/HIGH) automatically shifts to the next lower or higher range when 0 or 100% of the current range is reached.

Minimum value = 0% LOW range

Maximum value = 100% HIGH range

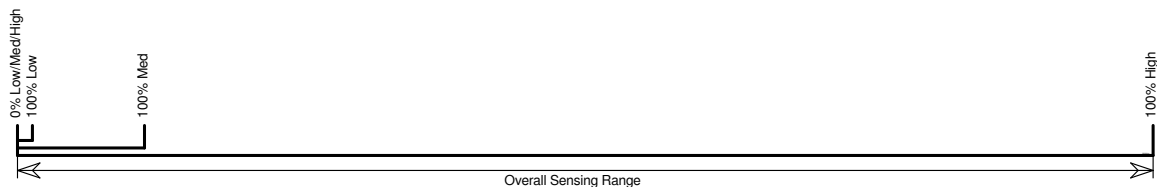

|                     |                            |
|---------------------|----------------------------|
| In the LOW range    | One yellow LED lights up   |
| In the MEDIUM range | Two yellow LEDs light up   |
| In the HIGH range   | Three yellow LEDs light up |

**The threshold value cannot be less than or equal to the current hysteresis value (if any).**

## DELAY TIME "TD"

Adjustable from 0.1 to 9.9 seconds (default value: 0.1 second).

## SWITCH BACK HYSTERESIS "HY"

Setting from 1 to 25% of the current measuring range.

After exceeding a threshold value (rising or falling), the corresponding contact relay will return to its rest position when the measured value has come back by the current hysteresis value.

**Reset hysteresis cannot be set to greater than or equal to the currently selected limit value!**

The default setting for hysteresis is 1%.

## TEMPERATURE MONITORING "TP" (TEMPERATURE PROTECTION)

Setting range: on/off

The connected probe is designed for a specific temperature range. If the permitted range is exceeded, this is indicated as an error. If this alarm function is not desired, temperature monitoring can be deactivated (Off).

**BAMO** INTERNATIONAL

22, Rue de la Voie des Bans · Z.I. de la gare · 95100 ARGENTEUIL

Tel +33 (0)1 30 25 83 20 Web [www.bamo.eu](http://www.bamo.eu)

Fax +33 (0)1 34 10 16 05 E-mail [export@bamo.fr](mailto:export@bamo.fr)

**TURBIDITY CONTROLLER  
TURBISWITCH GS5**

29-01-2024

M-410.03-EN-AD

**TUR**

**410-03/2**

## FAULT CONTACT

The contact is always closed when measurement functions correctly.

The fault contact opens in the event of a fault in the connected sensor.

The type of fault is indicated at the display (TR: receiver fault, TT: emitter fault). If measured turbidity is significantly greater than the maximum measuring range of the sensor, fault message TT (emitter fault) is displayed.

**All contacts are always open in the event of a fault.**

## RESET TO DEFAULT SETTINGS

Switch power supply on.

Within 3 seconds (i.e. during the test routine), press and hold the rotary/pushbutton selector for approximately 5 seconds:

The display counts up: 1, 2, 3, 4... 99 ST (ST = default values are loaded).

All settings are returned to their default values (factory settings).

## SWITCHING SUPPLY POWER ON (TEST ROUTINE)

After supply power has been switched on, the device starts a test routine during which all LEDs and the digital display are activated (LED test).

After about 5 seconds, the evaluation units software version is briefly displayed.

The display is then "limit value display".

## MEASURING RANGE

### FOR PIPE MOUNTED PROBES

Measurable turbidity values depend on the process medium and the nominal diameter of the piping.

Minimum acquirable turbidity in the LOW range begins at roughly 50...100 FAU.

Maximum detectable turbidity in the HIGH range: approx. 3000...10000 FAU (corresponds to approx. 10...30g/l SiO<sub>2</sub>).

Maximum detectable turbidity in the MEDIUM range: 10% of the HIGH range.

Maximum detectable turbidity in the LOW range: 1% of the HIGH range.

### FOR IMMERSION PROBES

Minimum detectable turbidity in the LOW range: starts at roughly 100...300 FAU

Maximum detectable turbidity in the HIGH range: approx. 30 000 FAU (corresponds to approx. 100g/l SiO<sub>2</sub>)

Maximum detectable turbidity in the MEDIUM range: 10% of the HIGH range

Maximum detectable turbidity in the LOW range: 1% of the HIGH range

**BAMO** INTERNATIONAL

22, Rue de la Voie des Bans · Z.I. de la gare · 95100 ARGENTEUIL

Tel +33 (0)1 30 25 83 20 Web [www.bamo.eu](http://www.bamo.eu)

Fax +33 (0)1 34 10 16 05 E-mail [export@bamo.fr](mailto:export@bamo.fr)

**TURBIDITY CONTROLLER  
TURBISWITCH GS5**

29-01-2024

M-410.03-EN-AD

**TUR**

**410-03/3**

## ELECTRICAL CONNECTION (HDR...)

For GA... measuring cells with transmitter / receiver TT-HDR and TR-HDR or TT-HDR5 and TR-HDR5

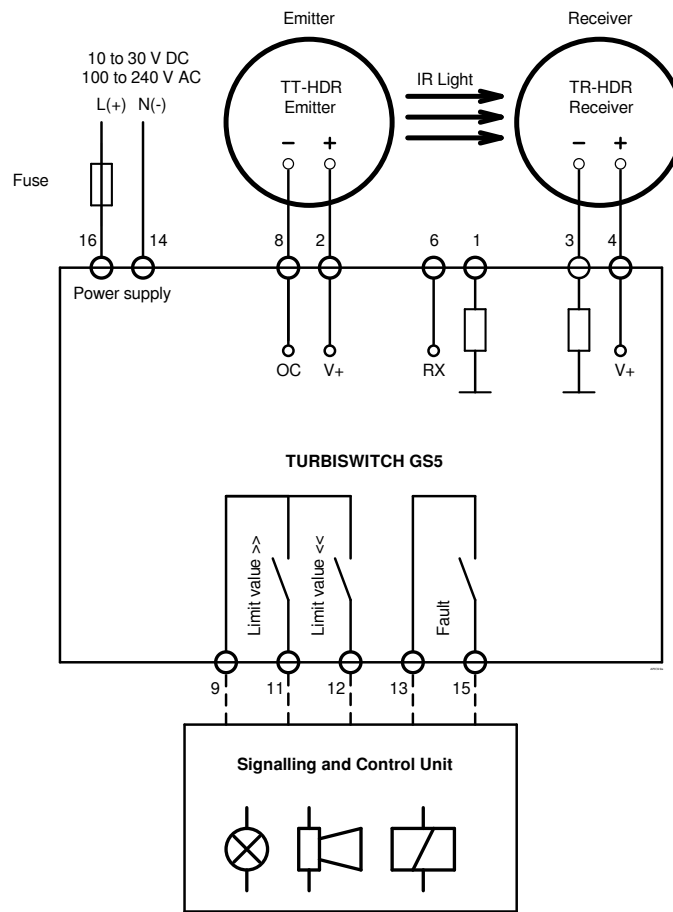

**BAMO** INTERNATIONAL

22, Rue de la Voie des Bans · Z.I. de la gare · 95100 ARGENTEUIL

Tel +33 (0)1 30 25 83 20 Web [www.bamo.eu](http://www.bamo.eu)

Fax +33 (0)1 34 10 16 05 E-mail [export@bamo.fr](mailto:export@bamo.fr)

**TURBIDITY CONTROLLER  
TURBISWITCH GS5**

29-01-2024

M-410.03-EN-AD

**TUR**

**410-03/4**

## ELECTRICAL WIRING (Immersion probe CP2 or CP5)

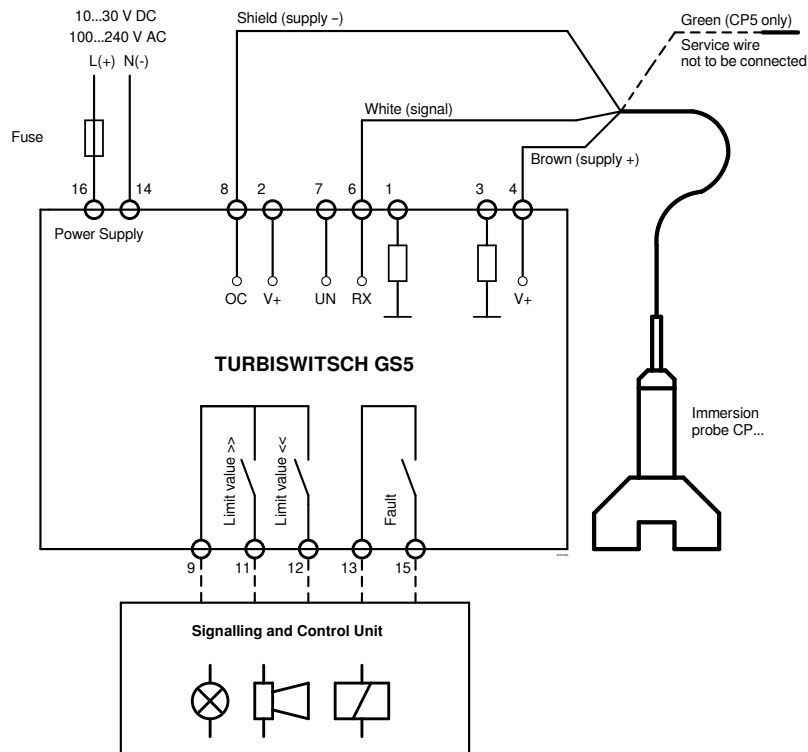

## SWITCHING LOGIC

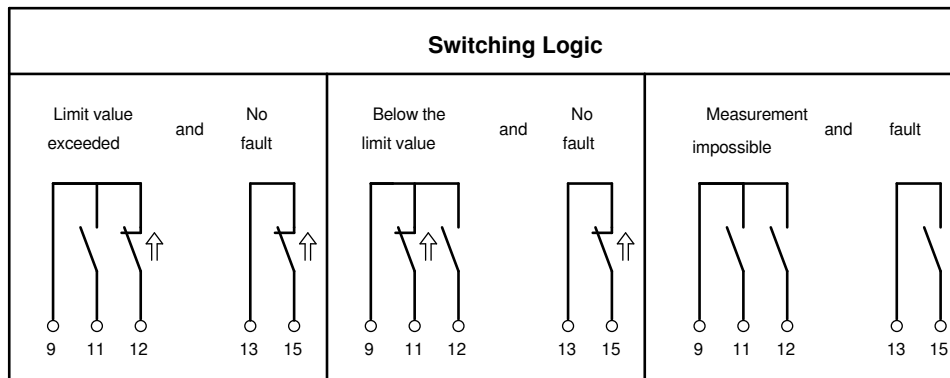

### Switching logic with increased reliability

The contacts open when one of the following events occur:

Contact 9-11 opens when measured value exceeds set limit value.

Contact 9-12 opens when measured value falls below set limit value.

Contact 13-15 opens in the event of a fault.

### Please note:

A connected PLC must react to the opening contact 13-15 in order to ensure a wire break monitoring.

If a fault occurs or in the event of power failure, all the contacts (9,11,12,13,15) are open.

**BAMO INTERNATIONAL**

22, Rue de la Voie des Bans · Z.I. de la gare · 95100 ARGENTEUIL

Tel +33 (0)1 30 25 83 20 Web [www.bamo.eu](http://www.bamo.eu)

Fax +33 (0)1 34 10 16 05 E-mail [export@bamo.fr](mailto:export@bamo.fr)

**TURBIDITY CONTROLLER  
TURBISWITCH GS5**

29-01-2024

M-410.03-EN-AD

**TUR**

**410-03/5**

## CONTROLS: ROTARY/PUSHBUTTON SELECTOR

### Turn

In menu level 0 the selected limit value is displayed and can be changed.

In menu level 1 reset hysteresis (HY), delay time (TD) or temperature monitoring (TP) can be selected.

In menu level 2 desired values for reset hysteresis and delay time (0.1 to 9.9 seconds) can be selected.

Anticlockwise rotation: -

Clockwise rotation: +

### Press

Press to select submenus.

Pressing the button in submenu 2 returns the display to menu 1.

Note:

Changed settings are saved immediately!

If the rotary/pushbutton selector is not operated for more than 7 seconds, the display returns automatically to menu level 0.

### Menu structure

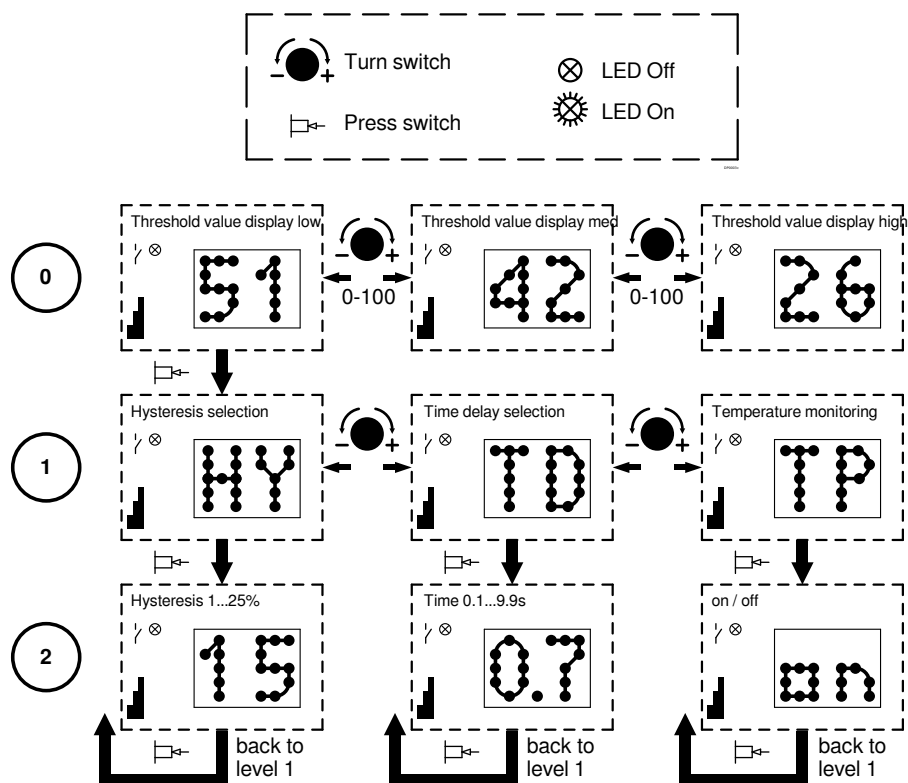

## SETTING THE THRESHOLD, LIMIT VALUE AND COMMISSIONING

Adjustment takes place after installation and electrical connection.

If problems arise, see "Troubleshooting".

All steps must be carried out in chronological order.

### Detecting the transition from the clear phase to sludge:

1. Turn the rotary/pushbutton selector on the evaluation unit clockwise as far as it will go until the display indicates 100% in the HIGH range. 3 LEDs light up yellow.
2. Fill the measuring cell with the clear phase or immerse the probe into the clear phase (blue LED is off).
3. Turn the rotary switch anticlockwise (-) until the blue LED lights up.
4. Slowly turn clockwise (+) until the blue LED goes out.  
The device now reacts as soon as the medium becomes slightly more turbid.
5. To prevent the TURBISWITCH GS5 from reacting to extremely slight deviations, adjust the switching point a bit further in the clockwise direction (+) (approx. 5 to 20 %).

**BAMO** INTERNATIONAL

22, Rue de la Voie des Bans · Z.I. de la gare · 95100 ARGENTEUIL

Tel +33 (0)1 30 25 83 20 Web [www.bamo.eu](http://www.bamo.eu)

Fax +33 (0)1 34 10 16 05 E-mail [export@bamo.fr](mailto:export@bamo.fr)

**TURBIDITY CONTROLLER  
TURBISWITCH GS5**

29-01-2024

M-410.03-EN-AD

**TUR**

**410-03/6**

## SETTINGS THE THRESHOLD, LIMIT VALUE AND COMMISSIONING (Continuation)

### Other settings and optimisation:

- If the ascertained limit value is below 10% in the HIGH or MEDIUM range, turn anticlockwise (-) to switch into the LOW range, thus permitting a more accurate adjustment.
- In order to avoid inadvertent switching due to any brief occurrence of gas bubbles or particles, switching contact delay time (TD) can be increased to as long as 9.9 seconds.
- Inadvertent switching in the event of switching point fluctuation can be avoided by increasing reset hysteresis (HY).

## TROUBLESHOOTING

| Error                                                        | Cause                                                                                                                                           | Remedy                                                                                   |
|--------------------------------------------------------------|-------------------------------------------------------------------------------------------------------------------------------------------------|------------------------------------------------------------------------------------------|
| The blue LED is always on.                                   | The limit value is too low.                                                                                                                     | Set a higher "Limit value"!                                                              |
|                                                              | Reset hysteresis is too high.                                                                                                                   | Set a lower "Reset Hysteresis" value!                                                    |
|                                                              | Turbidity exceeds the upper limit of the measuring range. (Especially if the measurement previously functioned in a permanently stable manner.) | Check the measuring cell for any impurities and remove them. Clean the glass discs!      |
| "TT" appears on the display or the HDR5 receiver blinks red. | Light from the emitter is not reaching the receiver.                                                                                            | Check/ Mount the emitter and/or receiver to the measuring cell.                          |
|                                                              |                                                                                                                                                 | Check the measuring cell for any impurities and remove them.                             |
|                                                              |                                                                                                                                                 | Clean the glass discs.                                                                   |
|                                                              |                                                                                                                                                 | The turbidity value is so high, that no light is reaching the receiver.                  |
| HDR5 emitter blinks red.                                     | Defective emitter.                                                                                                                              | Replace the emitter.                                                                     |
| "TR" appears on the display.                                 | The receiver has malfunctioned or it is not connected.                                                                                          | Check the connection of the receiver!                                                    |
| "ER" appears on the display.                                 | Digital transmission between the receiver and the GS5 is severely impaired.                                                                     | Check the cable, observe EMC environment, use a shielded cable.                          |
| "CR" appears on the display.                                 | An internal memory error has occurred.                                                                                                          | Reset to factory settings!                                                               |
| "HT" appears on the display.                                 | The maximum permissible temperature of the connected sensor has been exceeded.                                                                  | Comply with permissible temperature or switch off temperature monitoring in the TP menu! |
| "LT" appears on the display.                                 | The minimum permissible temperature of the connected sensor has been fallen short of.                                                           | Comply with permissible temperature or switch off temperature monitoring in the TP menu! |
| The switching point has shifted.                             | Deposits on the optical windows.                                                                                                                | Clean the glass discs!                                                                   |
|                                                              | The liquid level is too low.                                                                                                                    | Fill the measuring cell or immerse the probe!                                            |
|                                                              | An incorrect turbidity range has been selected.                                                                                                 | Change the turbidity range!                                                              |
|                                                              | The limit value is too low or too high.                                                                                                         | Adjust the limit value!                                                                  |

**BAMO** INTERNATIONAL

22, Rue de la Voie des Bans · Z.I. de la gare · 95100 ARGENTEUIL

Tel +33 (0)1 30 25 83 20 Web [www.bamo.eu](http://www.bamo.eu)

Fax +33 (0)1 34 10 16 05 E-mail [export@bamo.fr](mailto:export@bamo.fr)

**TURBIDITY CONTROLLER  
TURBISWITCH GS5**

29-01-2024

M-410.03-EN-AD

**TUR**

**410-03/7**